

A Control Technology to Achieve a Low Cost Flicker-Free Single Stage LED Driver with Power Factor Correction

Brian White, *Student Member, IEEE*,
Yan-Fei Liu, *Fellow, IEEE*

Department of Electrical and Computer Engineering
Queen's University
Kingston, ON, Canada
b.white@queensu.ca, yanfei.liu@queensu.ca

Xiaodong Liu

Key Lab of Power Electronics and Motion Control
Anhui University of Technology
Maanshan, Anhui, China
lxdong168@sina.com

Abstract — Conventional single-stage AC-DC LED drivers with a high power factor contain significant LED current ripple at twice the AC frequency. This paper proposes an average current modulation method that is capable of driving LEDs from a voltage with large AC ripple, while maintaining zero low frequency current ripple. This allows the energy storage capacitance to be reduced, avoiding the need for electrolytic capacitors and prolongs the life of the driver. The average current modulator requires a single low voltage MOSFET, a current sense resistor and a simple control circuit, which keeps the cost of the modulator low, and the impact on efficiency to a minimum. An 8.75 W experimental prototype has been built to verify the proposed design.

Keywords—LED lighting; energy efficiency; ripple-free; electrolytic capacitor;

I. INTRODUCTION

To reduce society's energy consumption, the use of light emitting diodes (LEDs) in residential and commercial lighting applications can offer both power savings and longer lamp lifetimes. As fluorescent lamps offer increased energy efficiency over traditional incandescent lighting, solid state lighting offers numerous benefits that will see it overtake fluorescent lighting as the dominant source of residential and commercial lighting [1, 2]. LED lamps offer higher luminous efficacy, longer lifetimes (50 000+ hours) and contain no hazardous materials such as Mercury.

The configuration of LED drivers has evolved to achieve the high efficiency and high power factor (PF), required by Energy Star regulations [3]. To meet these requirements, single stage power factor correction (PFC) converters can be employed to power LED lamps. While single stage PFC converters are easily able to obtain a high power factor, large energy storage capacitors are required to limit the current ripple within the LED load. A large capacitance necessitates the use of electrolytic type capacitors due to their high energy density. Electrolytic capacitors have significantly lower lifespans (~10 000 hours) than LED chips (~ 50 000 hours), and the use of these capacitors in LED drivers limits the overall life of the LED lamp. It is therefore desirable to utilize a single

stage PFC circuit that can provide a low output current ripple with a reduced amount of energy storage capacitance. Recently proposed LED drivers [4–5] have put forth altered single stage PFC drivers that can provide low LED current ripple with reduced energy storage capacitance. These works suffer from increased component costs, complicated control techniques, or relatively significant power losses.

An average current modulation method is proposed in this paper to operate in conjunction with single stage PFC drivers. A modulation switch in series with the LED load is controlled such that the average value of LED current is controlled each modulation cycle. The duty cycle of the modulation switch is varied throughout the low frequency variation of the PFC output voltage. Large duty cycles will occur at the minimum value of the PFC output, while lower duty cycles will occur at the maximum value of the PFC output.

The proposed modulation method features a simple control scheme, and only requires a single low voltage MOSFET (rated same as LED output voltage) to ensure zero low frequency current ripple to an LED load. The control method does not require a DC voltage to power the LED load, thus allowing a significant reduction in the energy storage capacitance of the PFC stage. The proposed design has been experimentally tested with a Buck-Boost prototype.

This paper is organized as follows. Section II explains the theory and operation of the proposed average current modulator, Section III showcases the experimental results, and Section IV presents the conclusions of the paper.

II. OPERATING PRINCIPLE OF THE PROPOSED AVERAGE CURRENT MODULATION METHOD

The proposed average current modulation method (current modulator) removes the low frequency LED current ripple that is normally generated by conventional single stage PFC LED drivers. The LED current is modulated at a fixed high modulation frequency (~25 kHz) by the modulation switch such that the average current of the LED load is controlled for each modulation cycle. The resulting LED current consists of a DC component and a high frequency component, at the

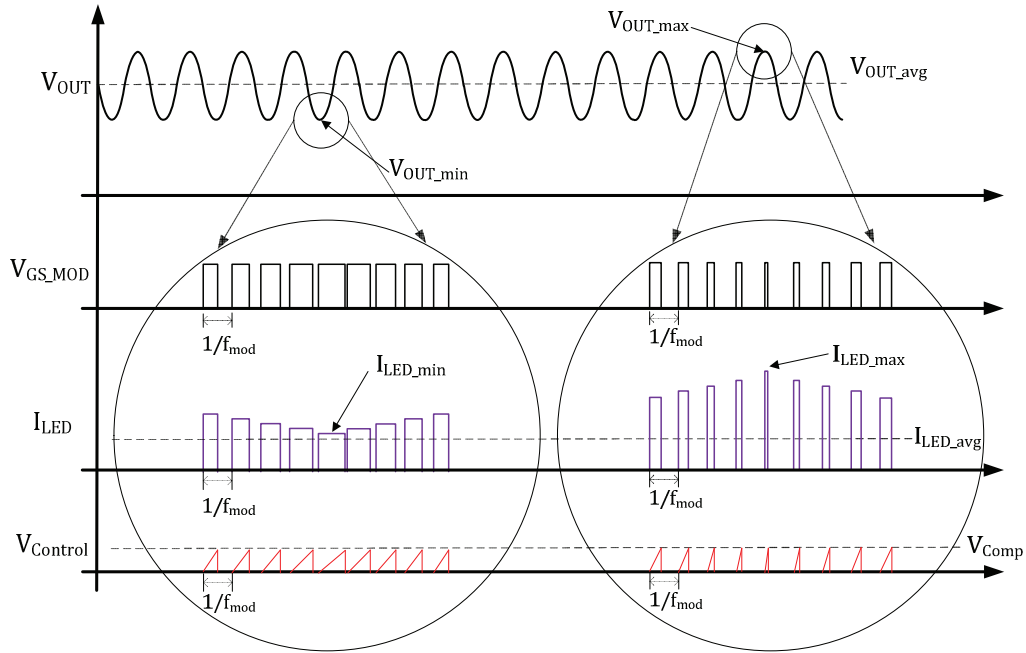

Fig. 1. Key Waveforms of the Average Current Modulator

modulation frequency. This modulation method removes any low frequency current ripple that would be induced by the voltage ripple of the PFC stage. The LED load will produce light that is proportional to the average LED current, and appear flicker-free as humans do not notice high frequency light modulation [6].

The modulation of LED current is illustrated in Fig. 1, which provides key waveforms of the current modulator's operation. Fig. 1 shows: the PFC output voltage (V_{OUT}), the modulation switch gate signal (V_{GS_MOD}), the LED load current (I_{LED}), and the integrated LED current signal ($V_{Control}$). The waveforms of Fig. 1 are zoomed in at the maximum, V_{OUT_max} , and minimum, V_{OUT_min} , values of the PFC output.

Each modulation cycle, the average current modulator turns the modulation switch on and integrates the LED current. Once the integrated current reaches the programmed level, the modulation switch is turned off. The amplitude of the LED current will vary with the instantaneous value of the PFC output voltage, thus the rate of integration will vary throughout the low frequency variation. This leads to a varying duty cycle of the modulation switch. As the average LED current is controlled at a high frequency, the current modulator is able to respond to significant low frequency voltage variation of the PFC output. Therefore, the average current modulator can ensure an LED current with zero low frequency content powered by a PFC circuit containing significant output voltage ripple.

A single stage PFC LED driver with the average current modulator added is illustrated in Fig. 2. The current modulator consists of a modulation switch (Q_{MOD}), a current sense resistor (R_{Sense}) and a control circuit. The control circuit is detailed in Fig. 3. The relatively low voltage rating for Q_{MOD} (the same as

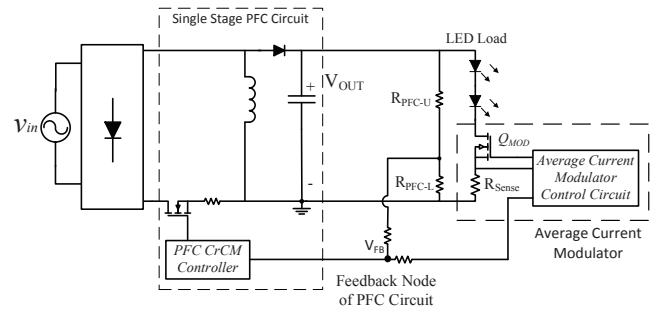

Fig. 2. Average Current Modulator within Single Stage PFC Circuit

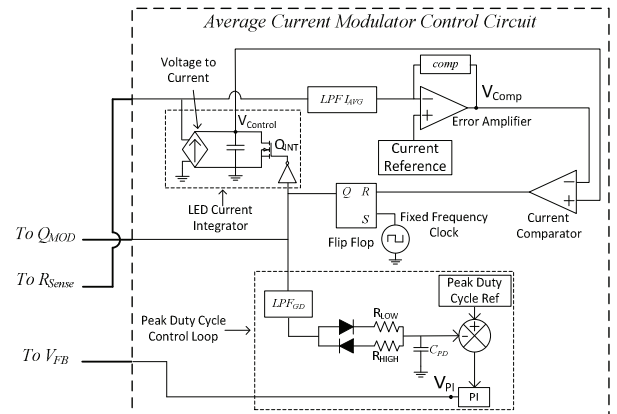

Fig. 3. Detailed Schematic of the Average Current Modulator Control Circuit

the LED voltage), and the simplicity of the control circuit keeps the cost of the modulator very low.

To control the modulation switch, the modulator instigates the switch turn-on at the beginning of each cycle via the flip flop and the clock. The LED current is sensed and integrated by the ‘LED Current Integrator’. Once the integrated current equals the error voltage, the current comparator instructs the flip flop to turn off the modulation switch. The error voltage is generated by the error amplifier, which compares the average LED current level, generated by filtering the LED current, to the current reference. As the PFC output voltage varies at twice the line frequency, the magnitude of the LED current pulses will vary at this frequency, such that the duty cycle will follow a sinusoidal shape.

To prevent damage to the LEDs, the maximum current pulse must be limited. It is noted that the maximum LED current pulse is offset from the minimum LED current pulse by a constant value. This value is dependent on the average LED current, the series resistance of the LED load, the capacitance used in the PFC stage and the AC frequency of the input voltage, as defined in (1).

$$I_{LED_max} - I_{LED_min} = \frac{I_{LED_avg}}{R_{LED} \cdot (2\pi \cdot f_{AC} \cdot C_{out})} \quad (1)$$

If the minimum LED current pulse can be controlled, the maximum LED current pulse can be limited. The minimum LED current pulse must be large enough to produce the desired average current with a duty cycle less than 100 %. If the duty cycle of the minimum LED current pulse (the peak duty cycle) is controlled, and set very high (e.g. 90 %), the minimum LED current pulse will be controlled and the maximum LED current pulse will be limited.

The peak duty cycle is detected within the ‘Peak Duty Cycle Control Loop’, shown in Fig. 3, by a unique sensing method. The gate drive signal of the modulation switch is first filtered by a low pass filter to produce a signal that represents the varying duty cycle of the modulation switch. This signal is then fed into a simplified peak detector which relies on two unidirectional sensing paths. The sensing paths, a forward (low impedance) path and a reverse (high impedance) path charge and discharge a capacitor to generate a voltage waveform representing the peak duty cycle. The path directions are controlled using diodes, and resistors are used to control the impedance of each path. When the duty cycle is high, the peak detect capacitor (C_{PD}) is quickly charged to a voltage representing the peak duty cycle through the low impedance path. During the rest of the low frequency period, the high impedance path discharges the capacitor slightly, enough to ensure stability but low enough that the capacitor voltage does not rise too high.

The average current modulator controls the peak duty cycle by adjusting the DC level of the PFC converter output voltage. An error signal is generated by the difference between the detected peak duty cycle and the desired peak duty cycle, which is connected to the feedback node of the PFC converter. The error voltage ensures that the output voltage level of the PFC converter is such that the minimum PFC voltage causes the desired peak duty cycle. The peak duty cycle control loop

inputs the gate signal of the modulation switch and outputs a control signal from a PI block (V_{PI}) to the feedback node of the PFC converter.

The feedback node voltage of the PFC converter is the combination of V_{PI} and the sensed output voltage. As V_{PI} changes, the output of the PFC converter will adjust such that the combination of voltages equals the reference voltage of the PFC controller. When the peak duty cycle is below the desired level, V_{PI} will increase, increasing the voltage of the feedback node. To balance the feedback voltage, the PFC output will decrease, and the LED current amplitude will decrease. The duty cycle will increase to maintain the average current. When the peak duty cycle is above the desired level, V_{PI} will decrease, decreasing the voltage of the feedback node. To balance the feedback voltage, the PFC output will increase, and the LED current amplitude will increase. The duty cycle will decrease to maintain the average current.

III. EXPERIMENTAL RESULTS

A prototype Buck-Boost LED driver was built to demonstrate the performance of the current modulator. A conventional driver with the same power structure was also constructed to provide a comparison against the performance of the proposed method. The output of both drivers is $\sim 50V / 175 mA$ for 8.75W of power from a 60 Hz AC supply. The Cree MLCAWT LED is used as the LED load, rated for a maximum current of 350 mA. The LED load consists of 14 chips, with a total series resistance of 37.38 Ω .

The LED driver is designed with significantly low energy storage capacitance, such that the PFC output will carry a voltage ripple of approximately 8 V_{pk-pk} , which is calculated to be 56 μF . The PFC circuit is implemented using the FAN7529 PFC Controller [7] from Fairchild.

To compare the performance of the average current modulator to the conventional design, the Fast Fourier Transform (FFT) of the LED current and measured LED light is taken. The DC and 120 Hz components are analyzed. The LED current of the conventional driver is shown in Fig. 4, with its FFT result. The measured LED light of the conventional

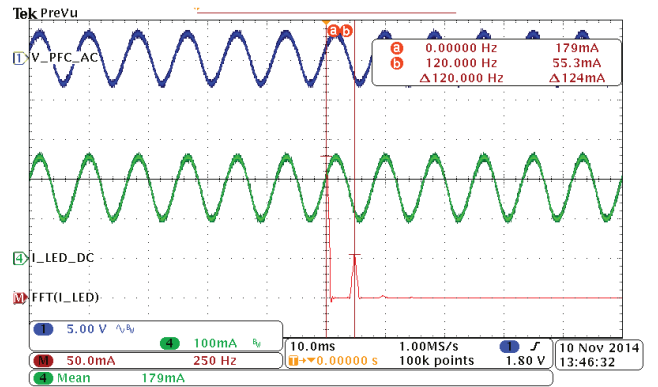

Fig. 4. Conventional Buck-Boost Driver – LED Current. CH1: PFC Output Voltage (AC Coupled; 5 V/div; 10 ms/div); CH4: LED Current (DC Coupled; 100 mA/div; 10 ms/div); MATH: FFT of LED Current (50 mA/div; 250 Hz/div).

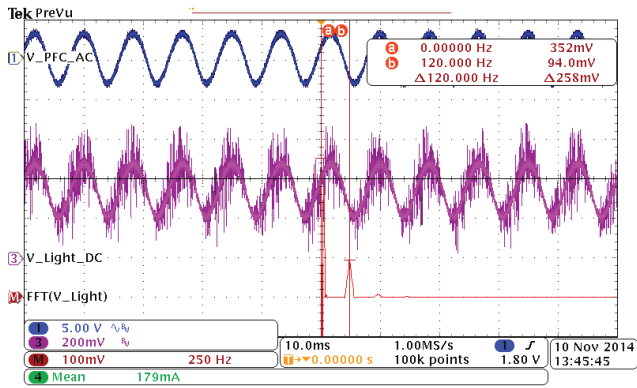

Fig. 5. Conventional Buck-Boost Driver – LED Light. CH1: PFC Output Voltage (AC Coupled; 5 V/div; 10 ms/div); CH3: LED Light (DC Coupled; 200 mV/div; 10 ms/div); MATH: FFT of LED Light (100 mV/div; 250 Hz/div).

driver is shown in Fig. 5, along with its FFT result. With the conventional driver design, the LED load has a 120 Hz ripple current of 55.3 mA_{rms} with a DC current of 179 mA, or a modulation index of 44%. Similarly, the measured 120 Hz of LED light is 94.0 mV_{rms} with a DC voltage of 352 mV, or a modulation index of 38%.

The average current modulator is then connected to the output of the conventional LED driver. The modulation frequency is set to 25 kHz, and a peak duty cycle of 90% is programmed. The modulator is configured using the UCC38C43 control IC from Texas Instruments, the IRFL014NPBFCT MOSFET from International Rectifier and a standard current sense resistor.

The waveform of the modulated LED current is presented in Fig. 6, along with its FFT result. Using the average current modulator, the 120 Hz component of the LED current has been reduced to 344 μA_{rms}, representing a modulation index of 0.27 % (344 μA * 1.414 / 177 mA). The modulator has reduced the 120 Hz current modulation index from 44 % to 0.27 %. The peak duty cycle of the LED current is shown in Fig. 7, where the current modulation has been zoomed in at the minimum value of the PFC output voltage. The minimum duty cycle is shown in Fig. 8, where the current modulation has been zoomed in at the maximum value of the PFC output voltage.

The waveform of the modulated LED light is presented in Fig. 9, along with its FFT result. Using the average current modulator, the 120 Hz component of the LED light has been reduced to 20.3 mV_{rms}, representing a modulation index of 9.1 % (20.3mV * 1.414 / 315mV). The modulator has reduced the 120 Hz light modulation index from 38 % to 9.1 %. This is below the limit of 9.6 % proposed in [6] for ‘Low Risk’ flicker at low frequencies. This limit was proposed by researchers studying the effects of health and safety risks of flicker in LED lighting, based on empirical data obtained from independent studies. The peak duty cycle of the LED light is shown in Fig. 10, where the light modulation has been zoomed in at the minimum value of the PFC output voltage. The minimum duty cycle is shown in Fig. 11, where the light modulation has been zoomed in at the maximum value of the PFC output voltage.

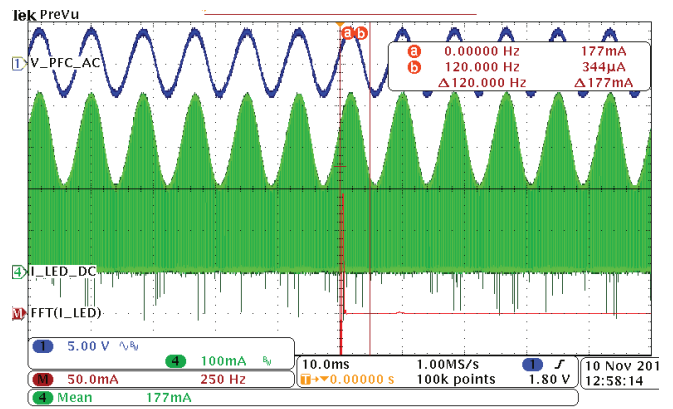

Fig. 6. Buck-boost output voltage ripple and LED current with average current modulator. CH1: PFC output voltage (ac coupled; 5 V/div; 10 ms/div). CH4: LED current (dc coupled; 100 mA/div; 10 ms/div). MATH: FFT of LED current (50 mA/div; 250 Hz/div).

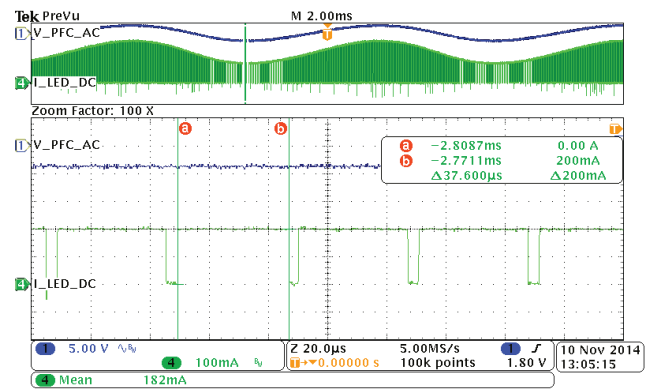

Fig. 7. LED current highlighting peak duty cycle. CH1: PFC output voltage (ac coupled; 5 V/div; 20 μs/div). CH4: LED current (dc coupled; 100 mA/div; 20 μs/div).

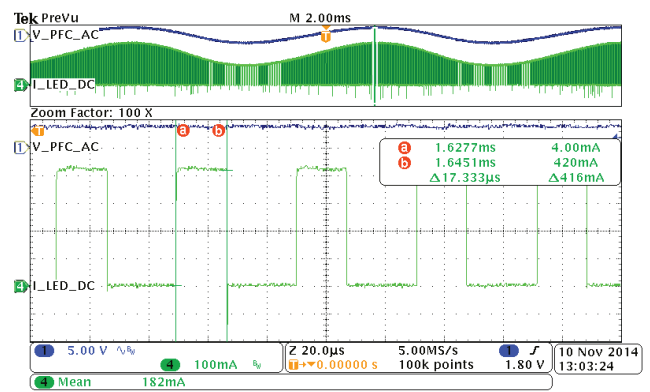

Fig. 8. LED current highlighting minimum duty cycle. CH1: PFC output voltage (ac coupled; 5 V/div; 20 μs/div). CH4: LED current (dc coupled; 100 mA/div; 20 μs/div).

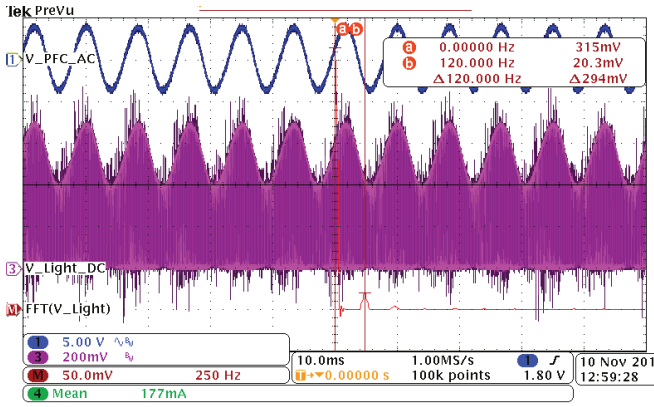

Fig. 9. Buck-boost output voltage ripple and LED light with average current modulator. CH1: PFC output voltage (ac coupled; 5 V/div; 10 s/div). CH4: LED light (dc coupled; 100 mA/div; 10 ms/div). MATH: FFT of LED current (50 mA/div; 250 Hz/div).

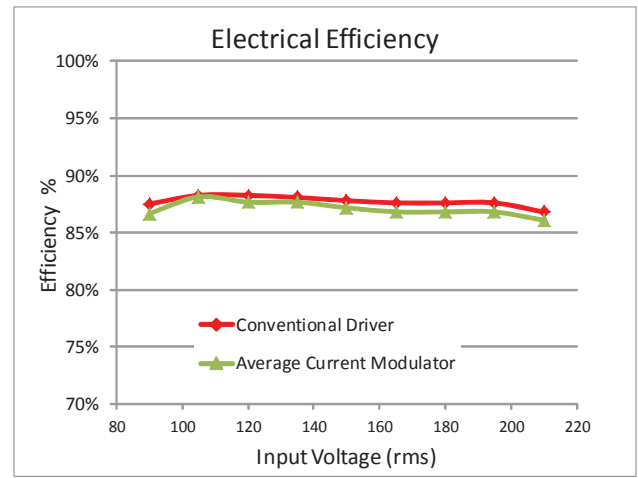

Fig. 12. Efficiency comparison with and without average current modulator

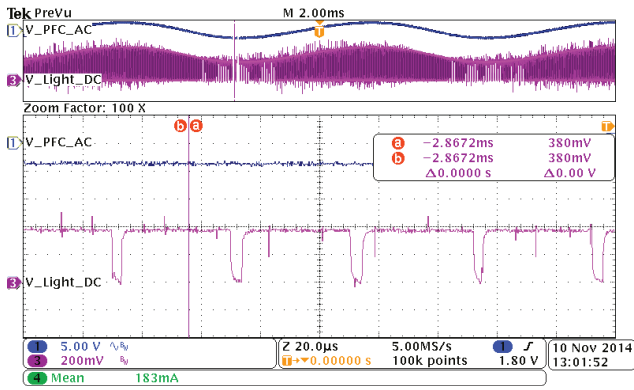

Fig. 10. LED light highlighting peak duty cycle. CH1: PFC output voltage (ac coupled; 5 V/div; 20 μ s/div). CH4: LED light (dc coupled; 100 A/div; 20 μ s/div).

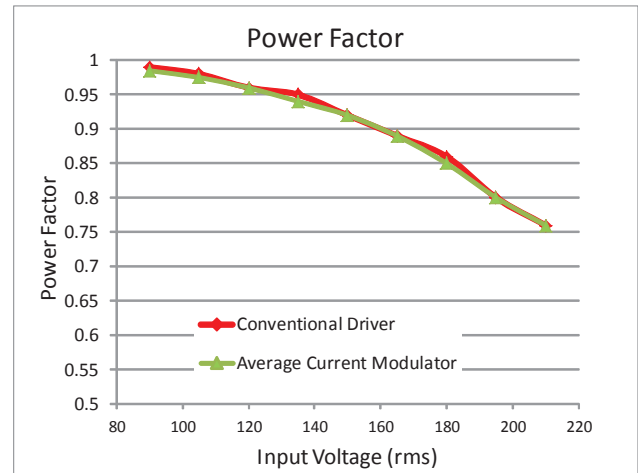

Fig. 13. Power factor comparison with and without average current modulator

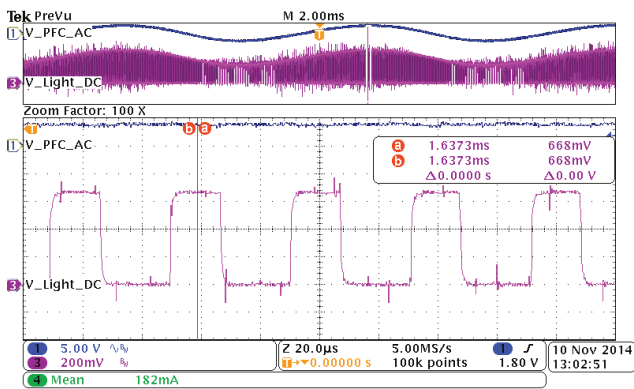

Fig. 11. LED light highlighting minimum duty cycle. CH1: PFC output voltage (ac coupled; 5 V/div; 20 μ s/div). CH4: LED light (dc coupled; 100 mA/div; 20 μ s/div).

The efficiency of both LED driver configurations are measured, and are shown in Fig. 12. It is observed that there is an efficiency drop of less than 1 % when the average current modulator is added. The input power factor of both driver configurations is also measured and plotted in Fig. 13. There is no discernible change in power factor when the current modulator is added.

IV. CONCLUSION

The average current modulation method proposed within this paper presents a novel control technique for driving LEDs from single stage PFC circuits. It provides minimized low frequency LED current with reduced PFC energy storage capacitance, allowing the use of ceramic or film type capacitors for long lamp lifetime. A peak duty cycle control method is implemented to limit the maximum LED current

pulse, preventing damage to the LED load. Experimental results of a lab tested prototype show that the low frequency current ripple can be limited to 0.27 %, and that the low frequency light ripple is limited below the tolerated boundaries defined by the industry. Requiring only a single low voltage MOSFET, current sense resistor and simple control circuit, the component cost is kept very low. The limited power loss leads to an efficiency drop of less than 1% when compared to conventional LED drivers.

REFERENCES

- [1] "GE Lighting Sees Brighter Future With LED Growth" *forbes.com*, last modified June 11 2013,
- [2] IMS Research, "\$10bn Market for LED Power Supplies in 2016" *lighting.com*
- [3] Standard: ENERGY STAR Qualifying Criteria for Solid Stage Lighting (SSL) Luminaires, Version 1.3, U.S. EPA, 2010
- [4] Yajie Qiu; Hongliang Wang; Zhiyuan Hu; Laili Wang; Yan-Fei Liu; Sen, P.C., "Electrolytic-capacitor-less high-power LED driver," Energy Conversion Congress and Exposition (ECCE), 2014 IEEE , vol., no., pp.3612,3619, 14-18 Sept. 2014
- [5] Peng Fang; White, B.; Fiorentino, C.; Yan-Fei Liu, "Zero ripple single stage AC-DC LED driver with unity power factor," Energy Conversion Congress and Exposition (ECCE), 2013 IEEE , vol., no., pp.3452,3458, 15-19 Sept. 2013
- [6] B. Lehman; A. Wilkins; S. Berman; M. Poplawski; N.J. Miller, "Proposing measures of flicker in the low frequencies for lighting applications," (ECCE), 2011 IEEE , vol., no., pp.2865,2872, 17-22 Sept. 2011
- [7] Fairchild Semiconductor, Datasheet "FAN7529, Critical Conduction Mode PFC Controller", April 2007